



Clinical Research Is it a New Paradigm?

Krathish Bopanna PhD, PhD, DSc

Chief Technology Officer

Manipal Acunova

Bangalore



- Healthcare Players
- Drug Development Process
- Clinical Trials : Definition
- Players in Clinical Research
- Regulatory, Phases, Roles in Clinical Research
- Benefits & risks of Clinical research
- Regulations in Clinical research
- Thoughts to Consider
- Clinical Research Market
- CRO Market, revenues, job opportunities
- Summary

Healthcare Industry Players

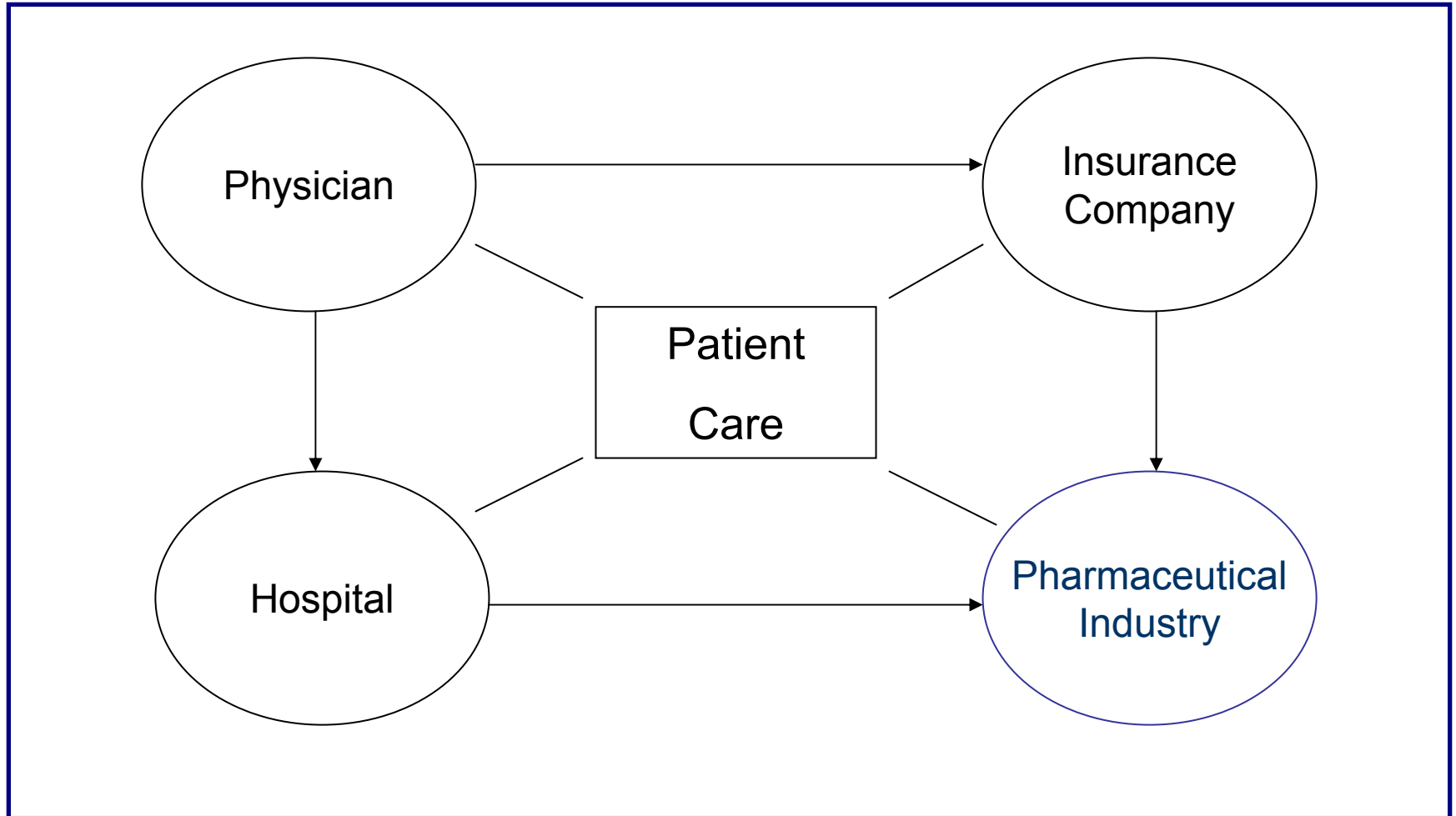

Drug Development Process

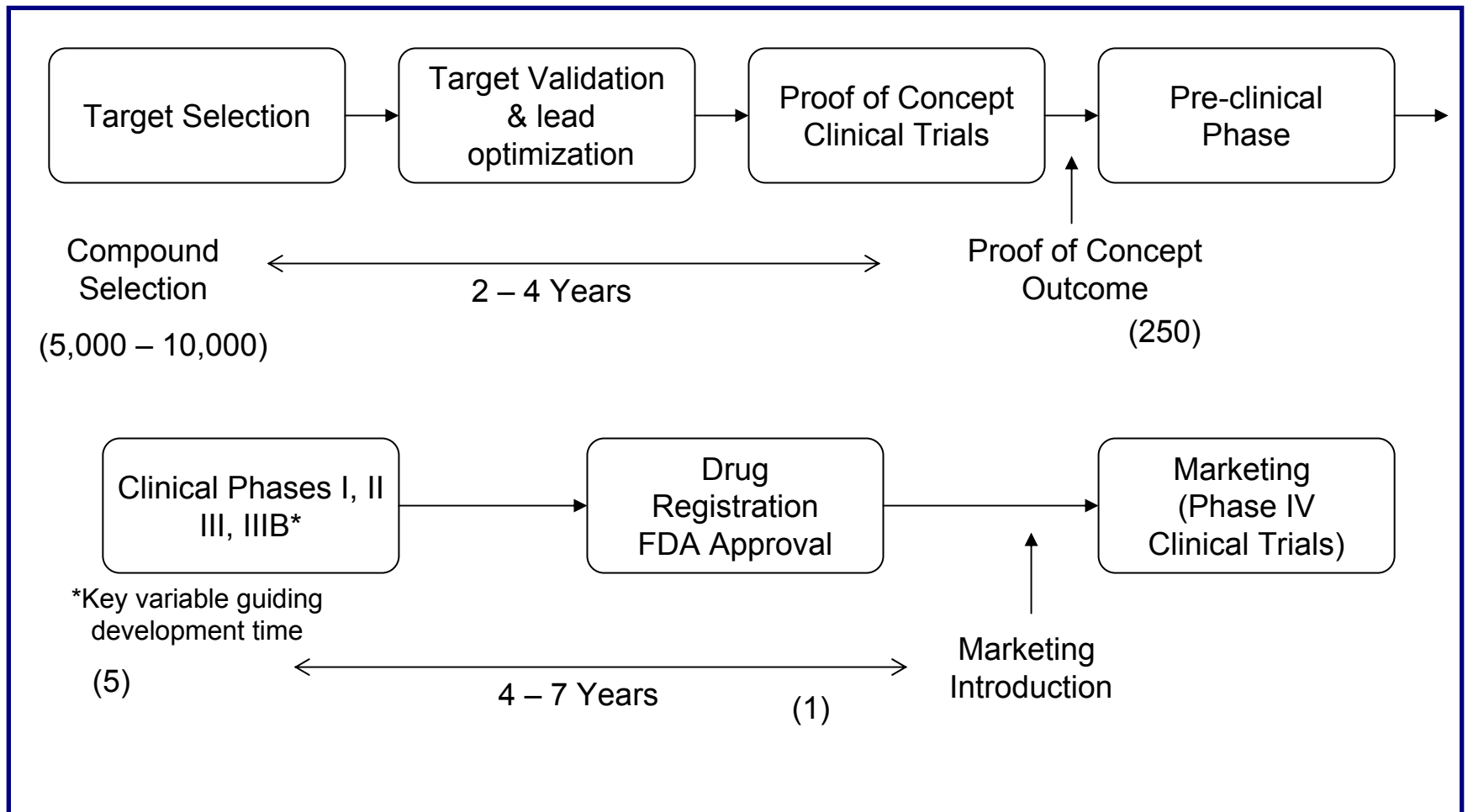

Clinical Trials: What Are They?



- *An organized research study designed to investigate new methods of preventing, detecting, diagnosing, or treating an illness or disease (such as cancer).*
- **Clinical:** Pertaining to humans (subjects volunteers, patients)
- **Research:** The study of material & sources in order to establish facts & reach new conclusions (analysis, enquiry, examination, experimentation, exploration, fact-finding, inquiry, investigation, probe, scrutiny, searching, study)

The Players in Clinical Research

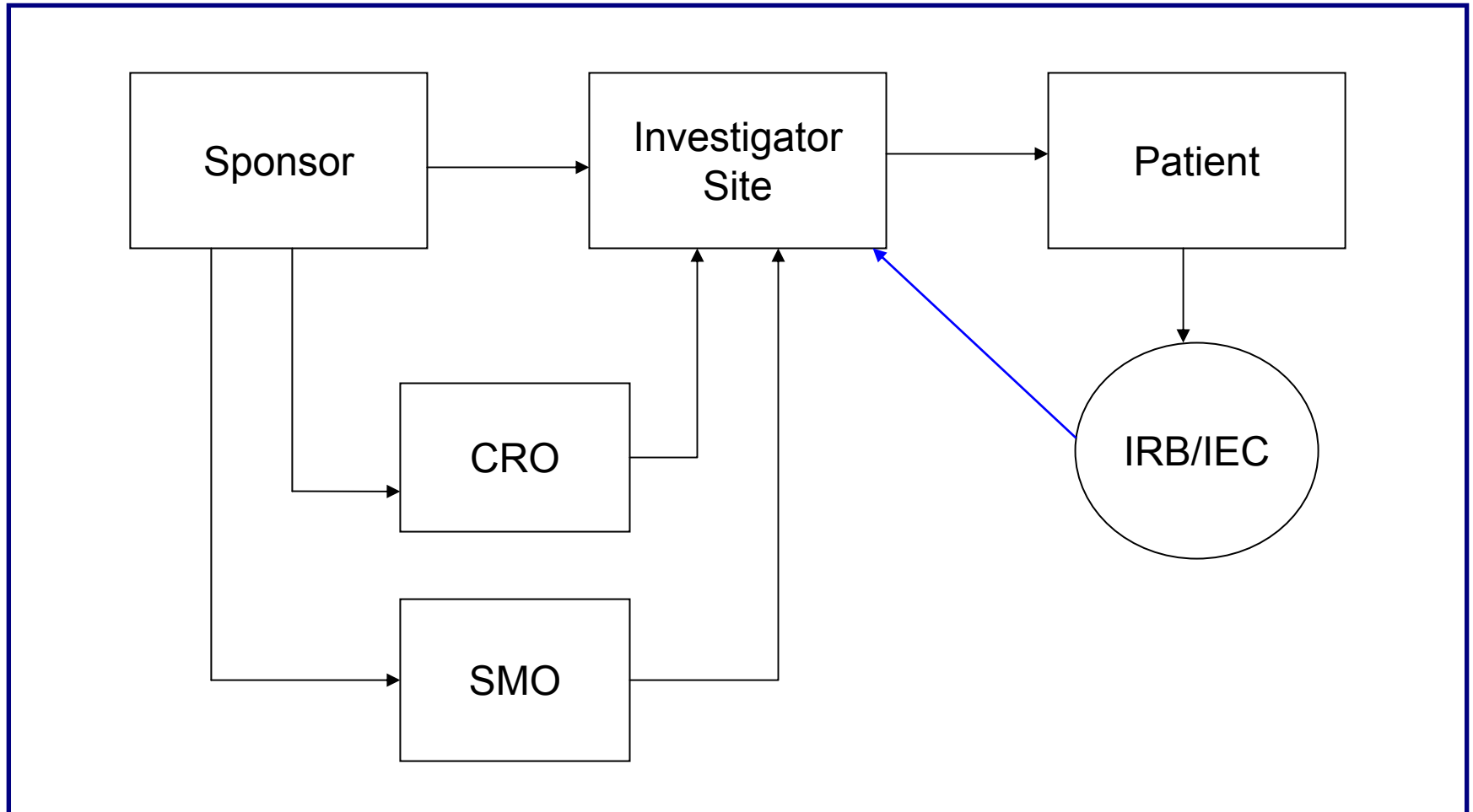

What is Involved in a Clinical Trial?

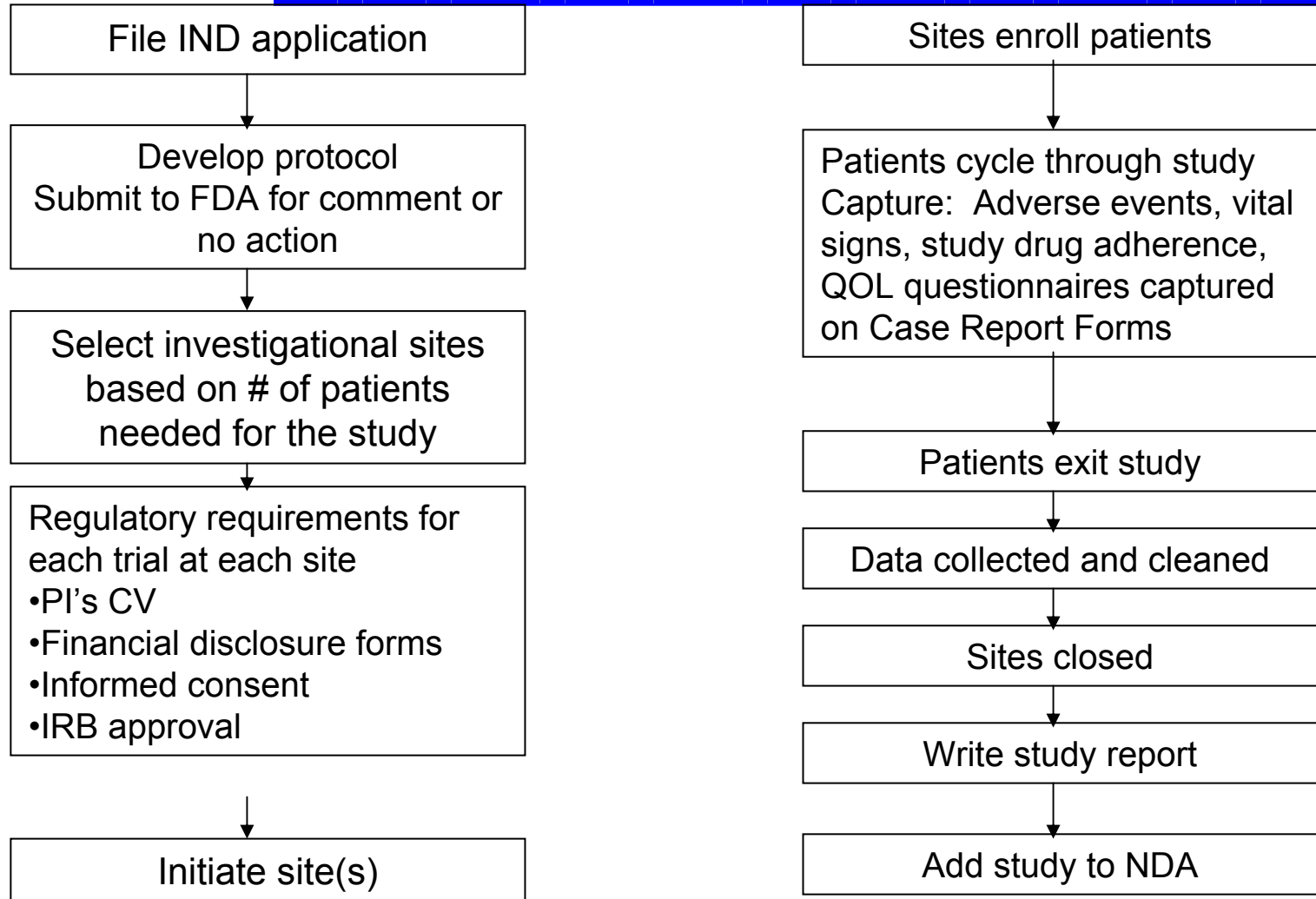

Clinical Trials Process and Associated Regulatory Process

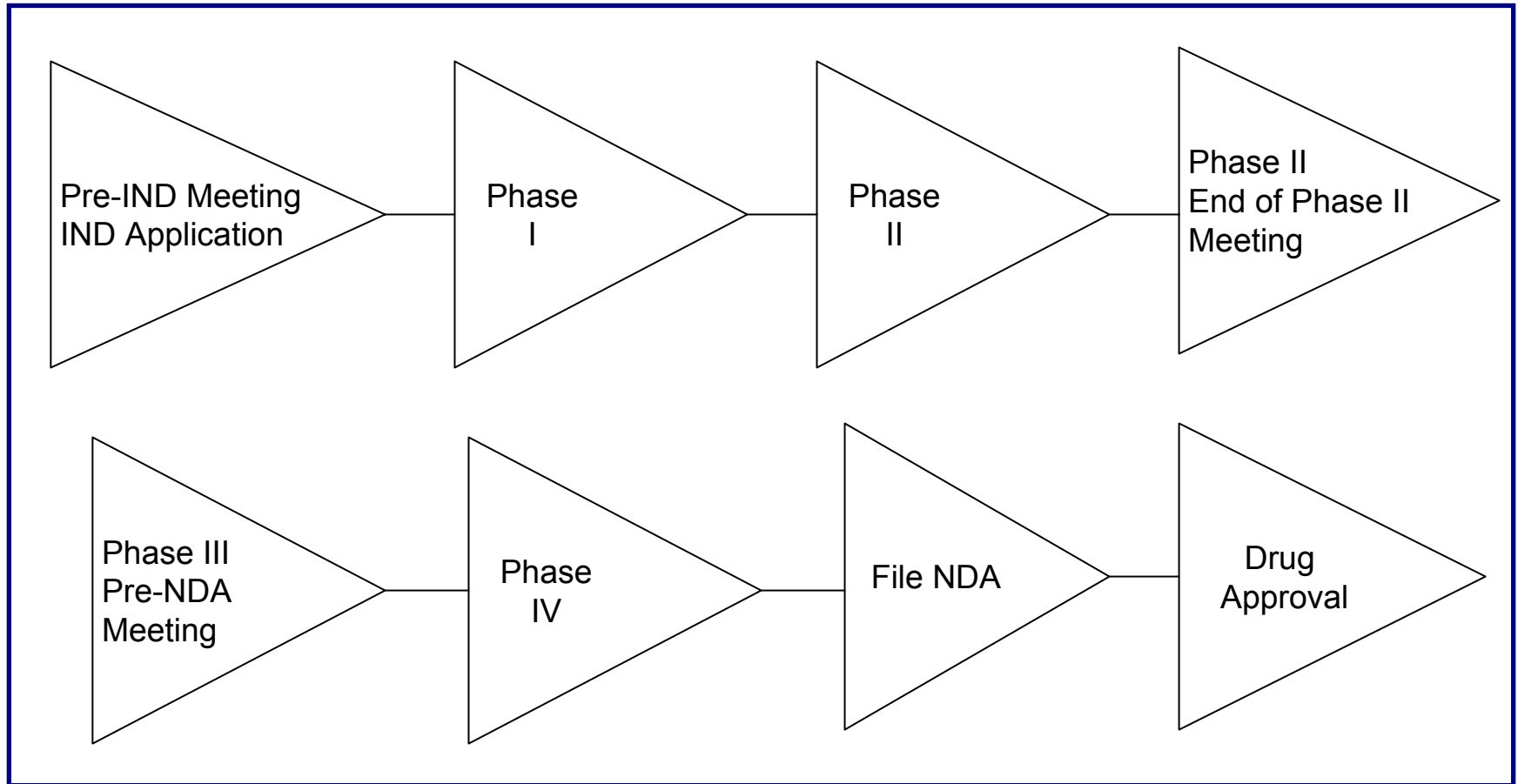

Phases of Clinical Trials



Category	# of Participants	Purpose
Phase I	Less than 10	Tests how to administer a new therapy, exam, or preventive option
Phase II	30-40	Test patients responses to a new therapy, exam, or preventive option
Phase III	100-1000+	Compares new therapy exam or preventive option to a standard one
Phase IV	Varies	For marketing purposes, to compare the effectiveness of two therapies already on the market or to study new uses of therapies

Tasks Involved in Clinical Trials



- Protocol development
- Volunteer recruitment
- Project Management
- Monitoring
- Data management
- Assurance of Drug safety
- Clinical statistics
- Medical writing
- Quality assurance
- Technology support



Possible Benefits of Trials	Possible Risks of Trials
<ul style="list-style-type: none"> • Having access to potentially more effective therapies than those currently available • Receiving quality medical care from leading physicians • Being closely monitored for possible negative effects • Sometimes receiving treatment at a reduced rate or free of charge • Helping to further new research that may result in significant medical advances • For patients in cancer therapy trials assigned to control groups, they still receive the top standard therapy available today 	<ul style="list-style-type: none"> • Patients may not receive the therapy under investigation (may receive a placebo – inactive pill – instead) • The new therapy may not be more effective than the standard, thoroughly tested therapy • In Phase I trails, not knowing the safety consequences of the new therapy (risk is less in Phase III trials) • New therapy may have unexpected, possibly severe side effects or may be less effective than standard of care • Insurance companies may not cover all costs of clinical trials

History Behind Regulations of Clinical Trials



- Regulations often result in response to abuse of human research subjects and concerns about the validity of data and conclusions from clinical trials.
- The primary vehicles for human subject protection are IRBs and informed consent.
- The Declaration of Helsinki and the Belmont Report are critical documents for the protection of human subjects in research.
- The FDA, by means of PDUFA and FDAMA, has made significant gains in speeding the process of making new drugs available for patients who need them.
- Current problems with clinical trials and trial oversight may well lead to increased regulation.

Regulations for Clinical Trials



- The FDA regulations pertaining to clinical trials are found in 21 CFR Parts 11, 50, 54, 56, 312 and 314.
- The ICH Guidelines for Good Clinical Practice should be followed in clinical trials.
- The FDA publishes many guidelines and information sheets pertaining to the appropriate conduct of clinical trials.
- Good clinical practices are the ethical and clinical standard for designing, conducting, analyzing, monitoring and reporting on clinical trials.

Thoughts to Consider



- ↙ R&D Investment is high
 - ↙ There is pressure on companies to perform
 - ↙ The pipeline is exploding
 - ↙ Sales growth is strong
- ↙ *How do all these positive factors impact employment in our industry?*

Clinical Research Market



Year	Indian market (Rs. in cr.)	Indian Market (million \$) [% of global]	Global Market (million \$)
2003	315	70 [1.16 %]	5000 - 6000
2004	450	100 [1.11 %]	9,000
2005	810	180 [1.80 %]	10,000
2007	2700	600 [2.26% of US]	26,500 US + Rest
2010	4500	1,000 [2 %]	50,000

*est McKinsey 2003
 Assumption USD = Rs. 45*

3-Year Employment Growth Global Pharmaceutical Industries



Growth rate

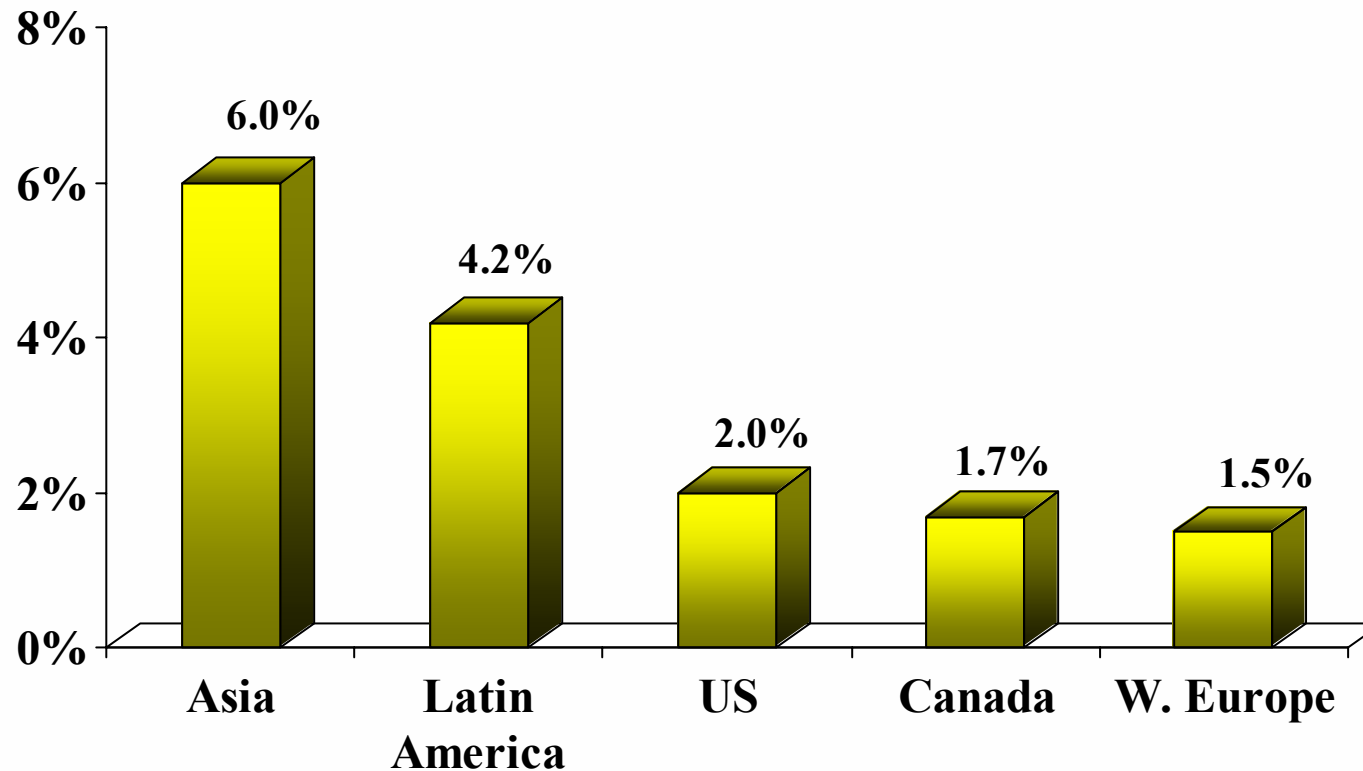

Allocation of R&D Personnel by Function

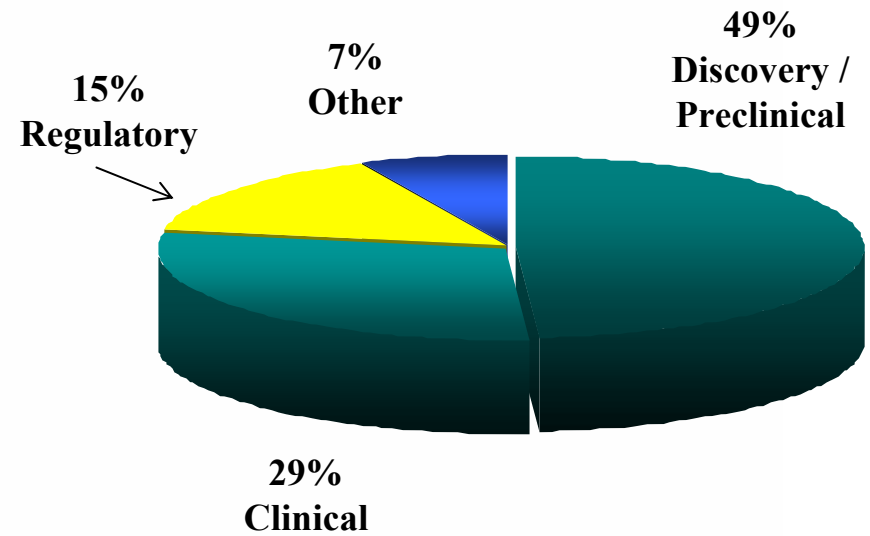
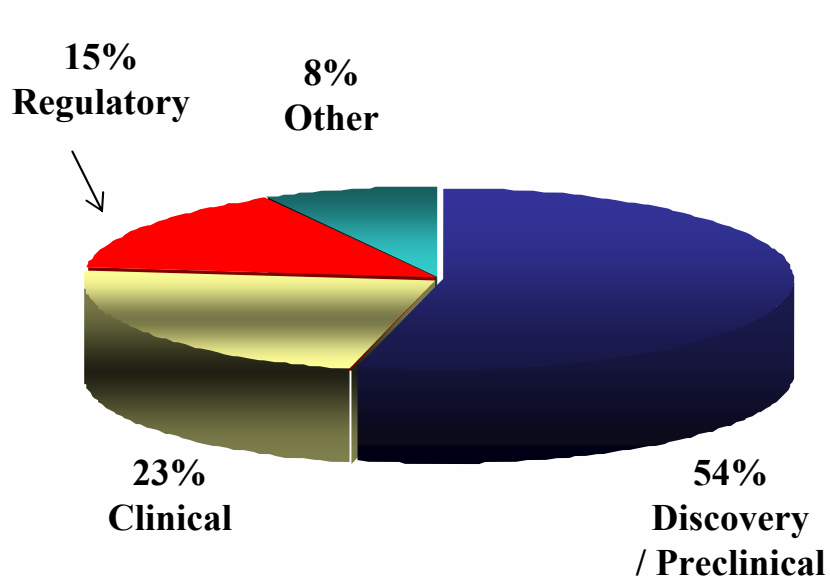

CRO Industry at a Glance



CRO - Revenues



CRO - Industry Analysis



**CRO Industry Analysis: 2004 Market
(in US billions)**

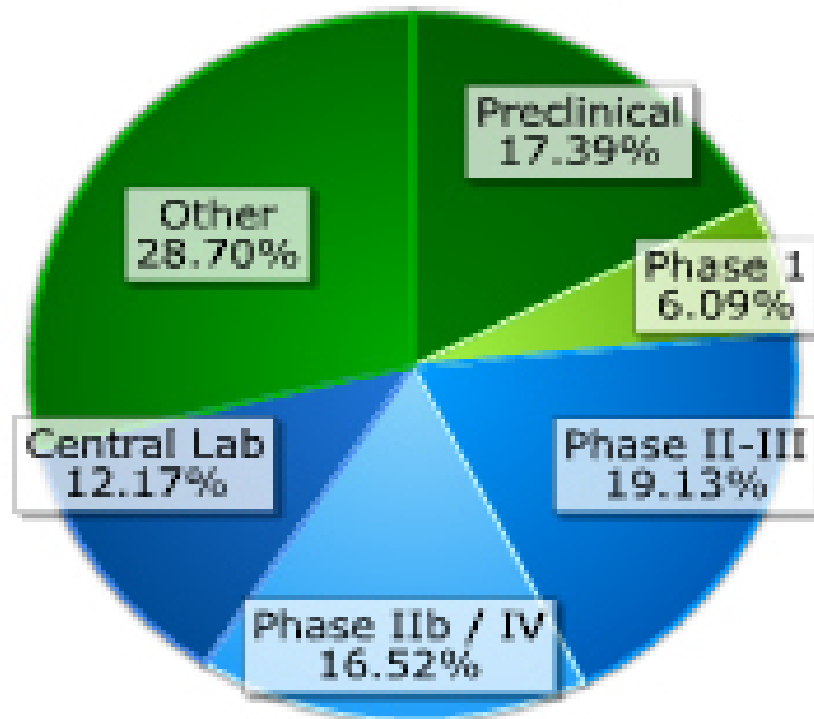

Top 20 CROs in India

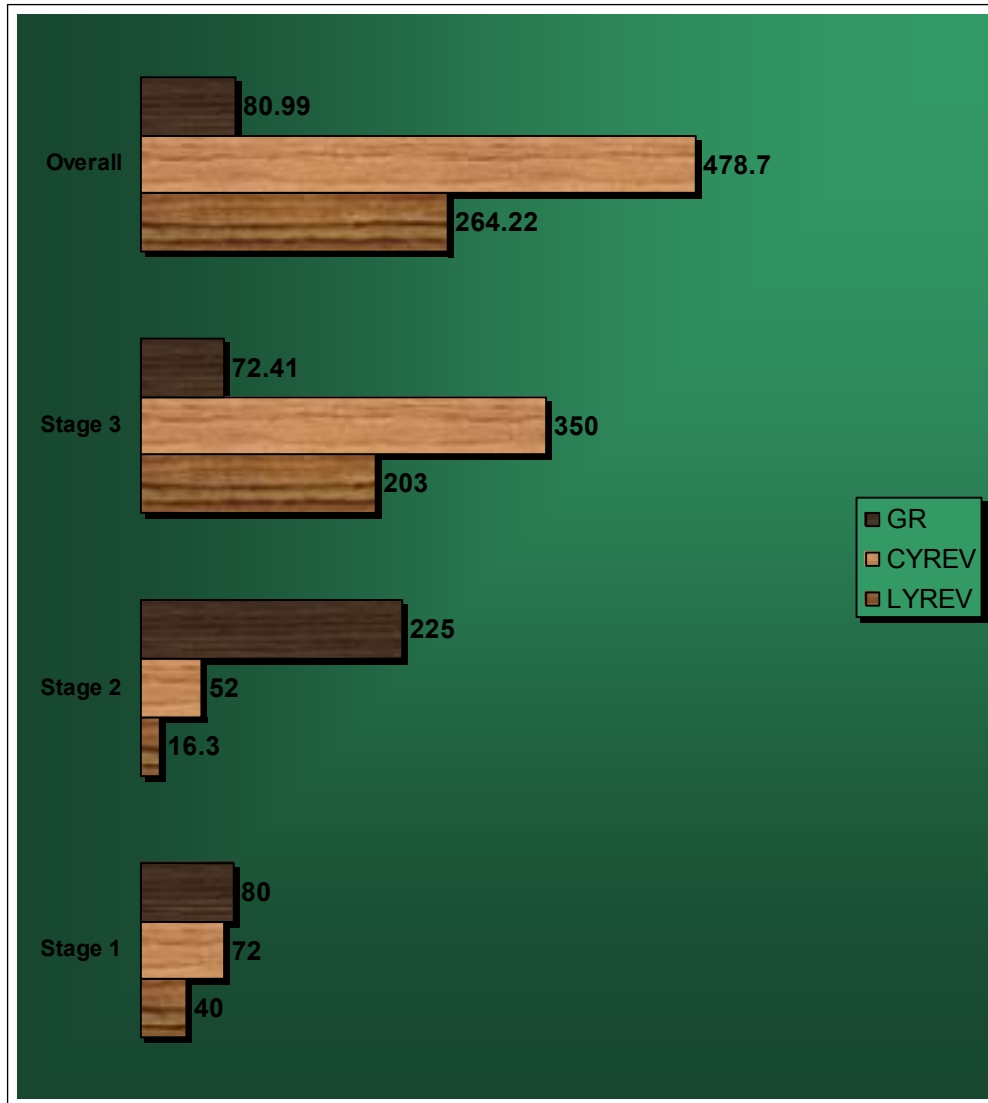

Source: Data on File

Staff Distribution in Indian CROs

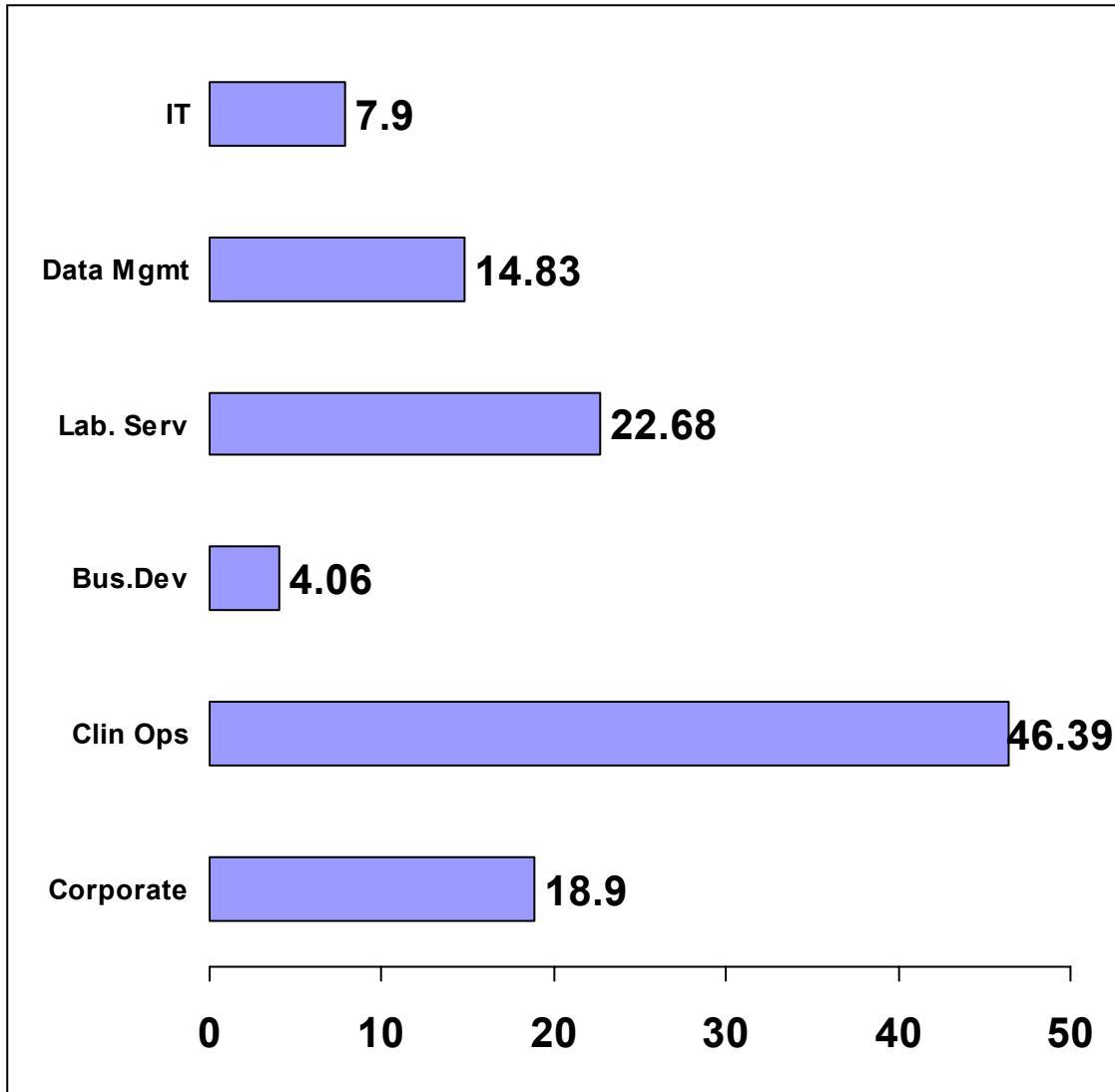

Source: Data on File

MNC Pharmacos in Clinical Research



- Abbott, Mumbai
- Chiron, Mumbai
- Astra Zeneca Pharma India Ltd, Bangalore
- AstraZeneca Foundation, Bangalore
- Aventis Pasteur, Delhi
- Pfizer Ltd, Mumbai
- Pfizer Biometrics, Mumbai
- Altana (Zydus), Mumbai
- Lilly, Delhi
- Boston Scientific, Delhi
- Hospira, Delhi
- Merck, Delhi
- Sanofi Aventis Syntho Lab, Mumbai
- **GSK, Glaxo SmithKline Pharmaceuticals Ltd, Mumbai**
- **Novartis International Clinical Development Center, Mumbai**
- **Novartis Pharma, Mumbai**
- **Roche, Mumbai**
- **Sandoz, Mumbai**
- **Wyeth, Mumbai**
- **BMS, Mumbai**
- **Novo Nordisk, Bangalore**
- **Lundbeck, Bangalore**
- **Eisai Pharmaceuticals, Mumbai**
- **LG Life Sciences, Delhi**
- **Bayer, Mumbai**
- **GE, Delhi**
- **Johnson & Johnson, Jansenn Cilag, Mumbai,**
- **CordiBaxter, Delhi**
- **BD Biosciences, Delhi**

These sponsors outsource work from the parent clinical development headquarters as well as have a clinical development unit located in India. Several have entered 2003-05 and many more are setting up at brisk pace.

Indian Pharmacos in Clinical Research



- **Bharat Biotech, Hyderabad**
- **Bharat Serum, Mumbai**
- **Cadila Pharmaceuticals**
- **Cipla, Mumbai**
- **Emcure, Pune**
- **Fulford India, Mumbai**
- **Indus Biotherapeutics, Ahmedabad**
- **IPCA, Mumbai**
- **Shreya Biotech, Pune**
- **Shantha Biotechnics Pvt. Ltd. Hyderabad**
- **Sun Pharma, Mumbai**
- **Torrent Pharmaceutical Ltd, Gandhi nagar,**
- **USV Ltd. Mumbai**
- **Wockhardt, Mumbai**
- **Zydus Cadilla, Ahmedabad**
- **Biocon, Bangalore**
- **Cadila Pharmaceuticals, Ahmedabad**
- **Intas Pharmaceuticals Ltd. Ahmedabad**
- **Glenmark Pharmaceuticals Ltd.**
- **Himalaya Drugs, Bangalore**
- **Lupin Ltd. Pune**
- **Nicholas Piramal, Mumbai**
- **Panacea Biotech, Delhi**
- **Ranbaxy Research Laboratories Delhi**
- **Ranbaxy Research Laboratories, Gurgaon**
- **Serum Institute of India, Pune**
- **Torrent, Ahmedabad**

Business Challenges

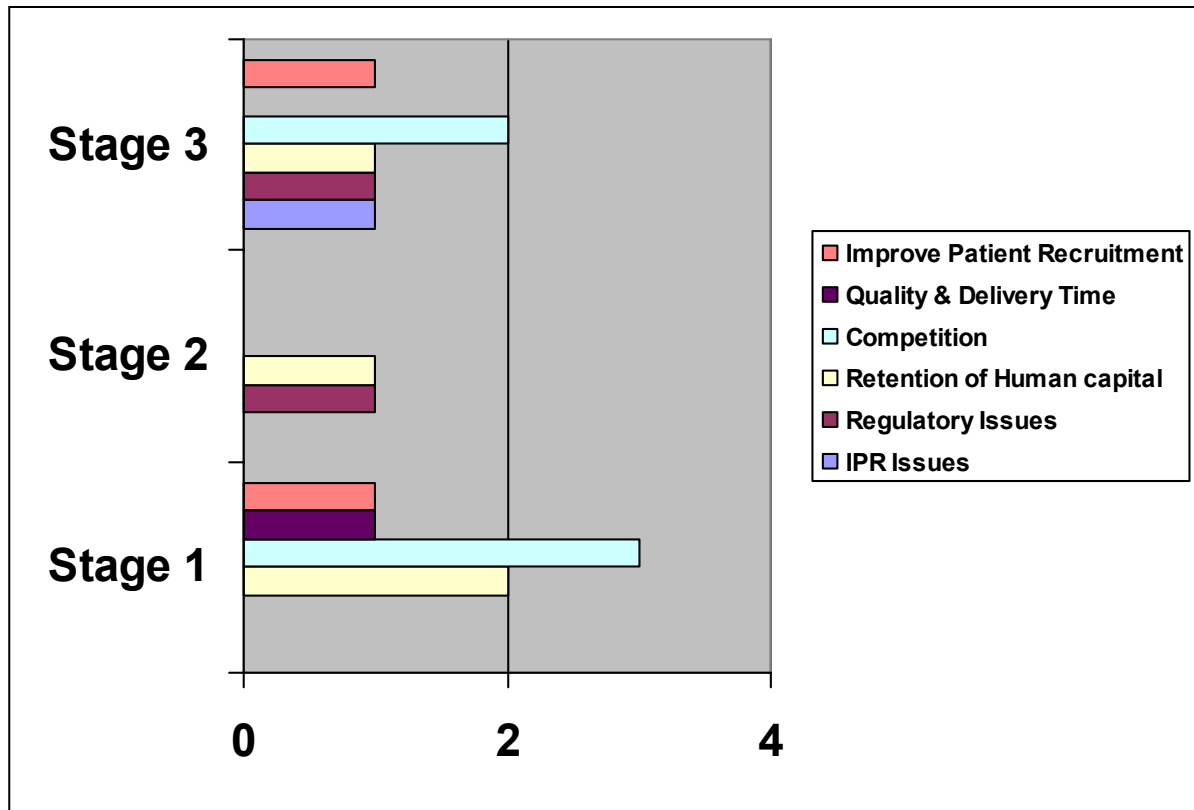

CRO (Clinical Research Organizations)



- CROs provide product development services to the pharmaceutical, biotechnology, and medical device industries allowing their clients to manage product development efforts more efficiently & cost-effectively.
- CROs employ some 100,000 professionals around the world.
- CRO market size is estimated at \$12 billion and growing. Revenue is increasing at an annual rate of 14-16 %.

Source: Center Watch Estimates, World Contract Research Organizations Markets, Frost & Sullivan, 2003
PARAXEL's Pharmaceutical R&D Statistical Sourcebook 2003/2004

CRO Industry Facts & Figures



- According to an independent analyst, clinical trials conducted by CROs are completed at an average of 30% more quickly than those conducted in-house. This results in an average time-saving of some 4-5 months translating to \$120 million to \$150 million in increased revenue potential.
- This is based on market expectation that an average product generates \$1 million in revenues every day.

Source: PARAXEL's Pharmaceutical R&D Statistical Sourcebook 2004/2005

Jobs!

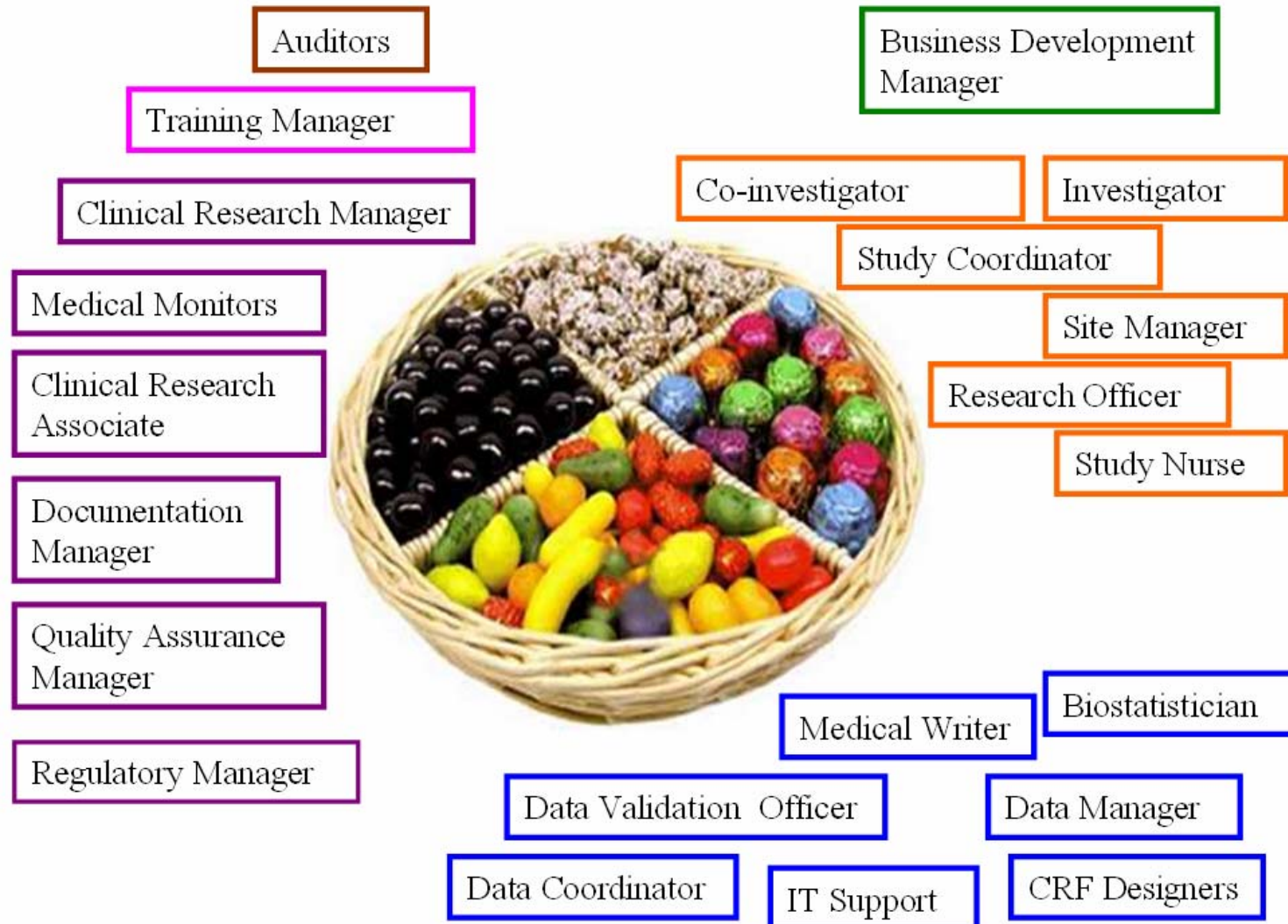

Key Qualifications Sought

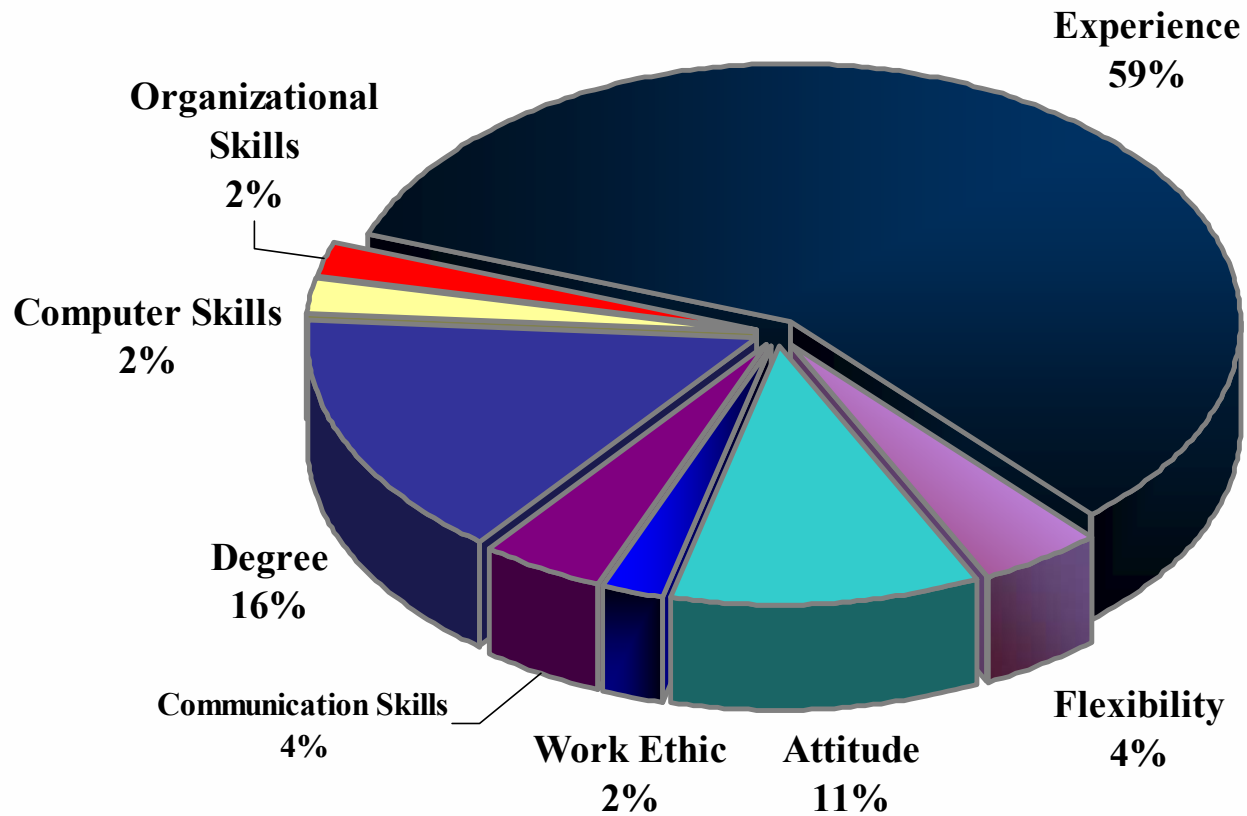

Demands on Position

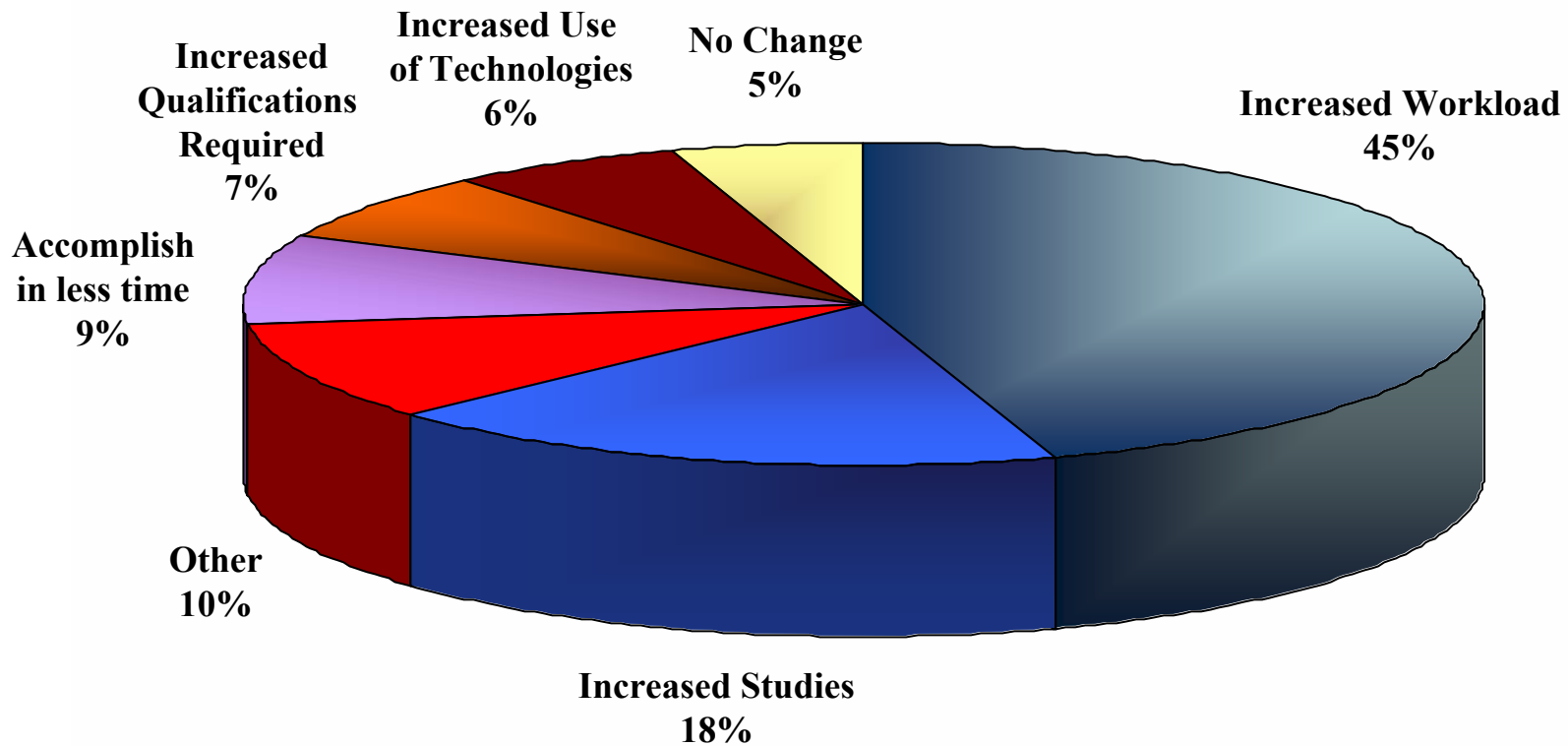

Changes in Roles & Responsibilities During Past 3 Years

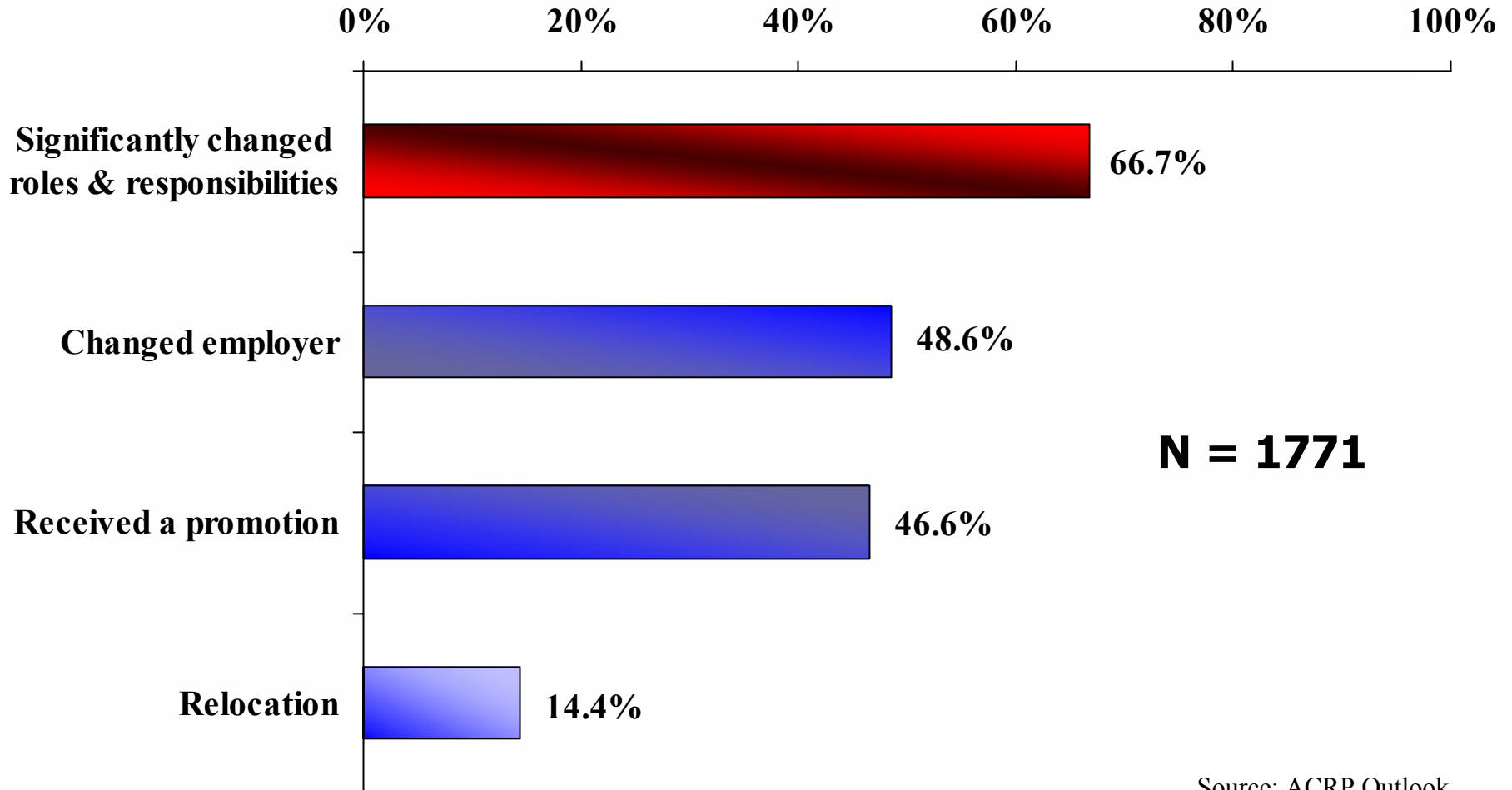

Salaries by Function

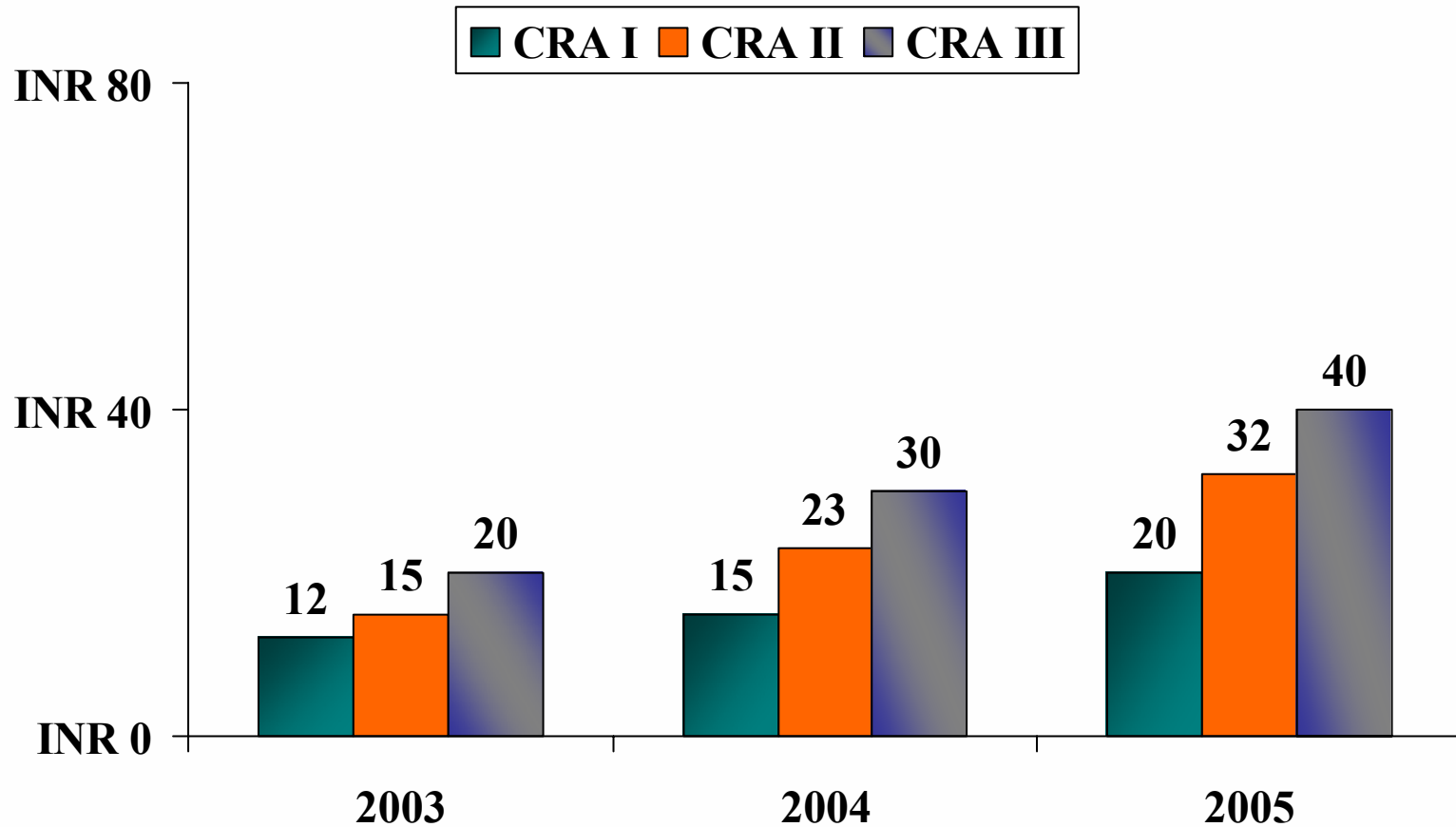

Source: Data on File

Salaries by Function

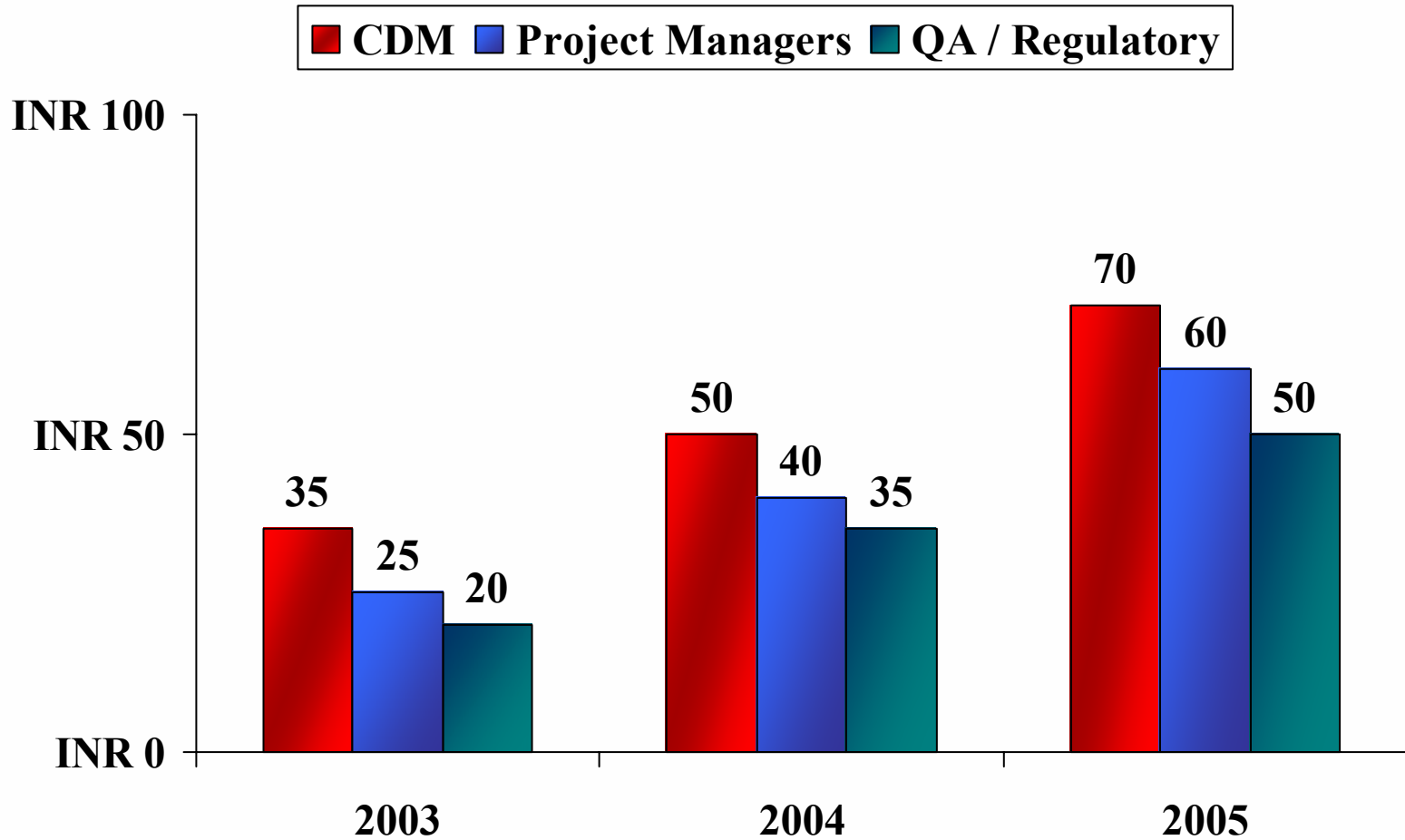



Percent of Total

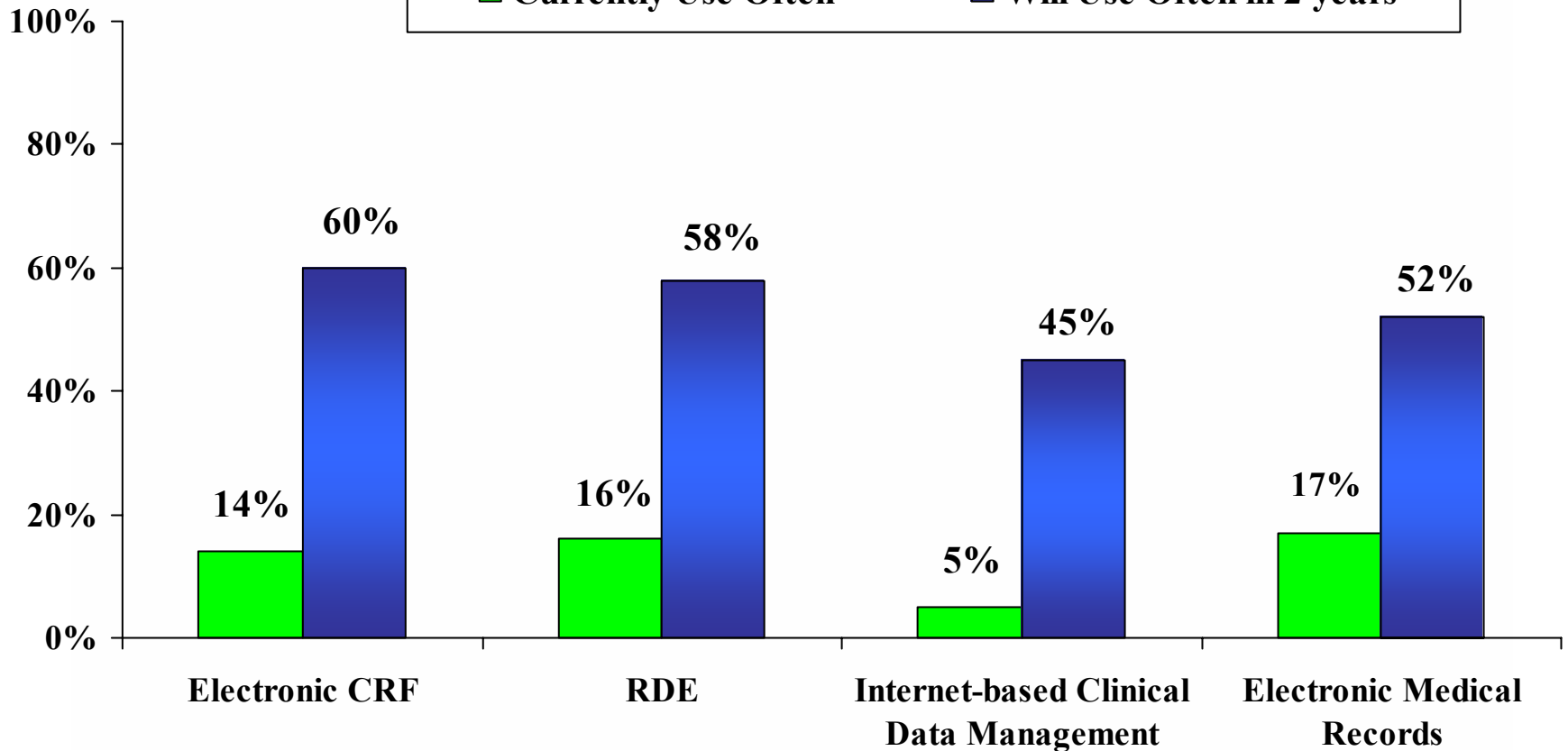

Source: ACRP Outlook,

Business Process Flow

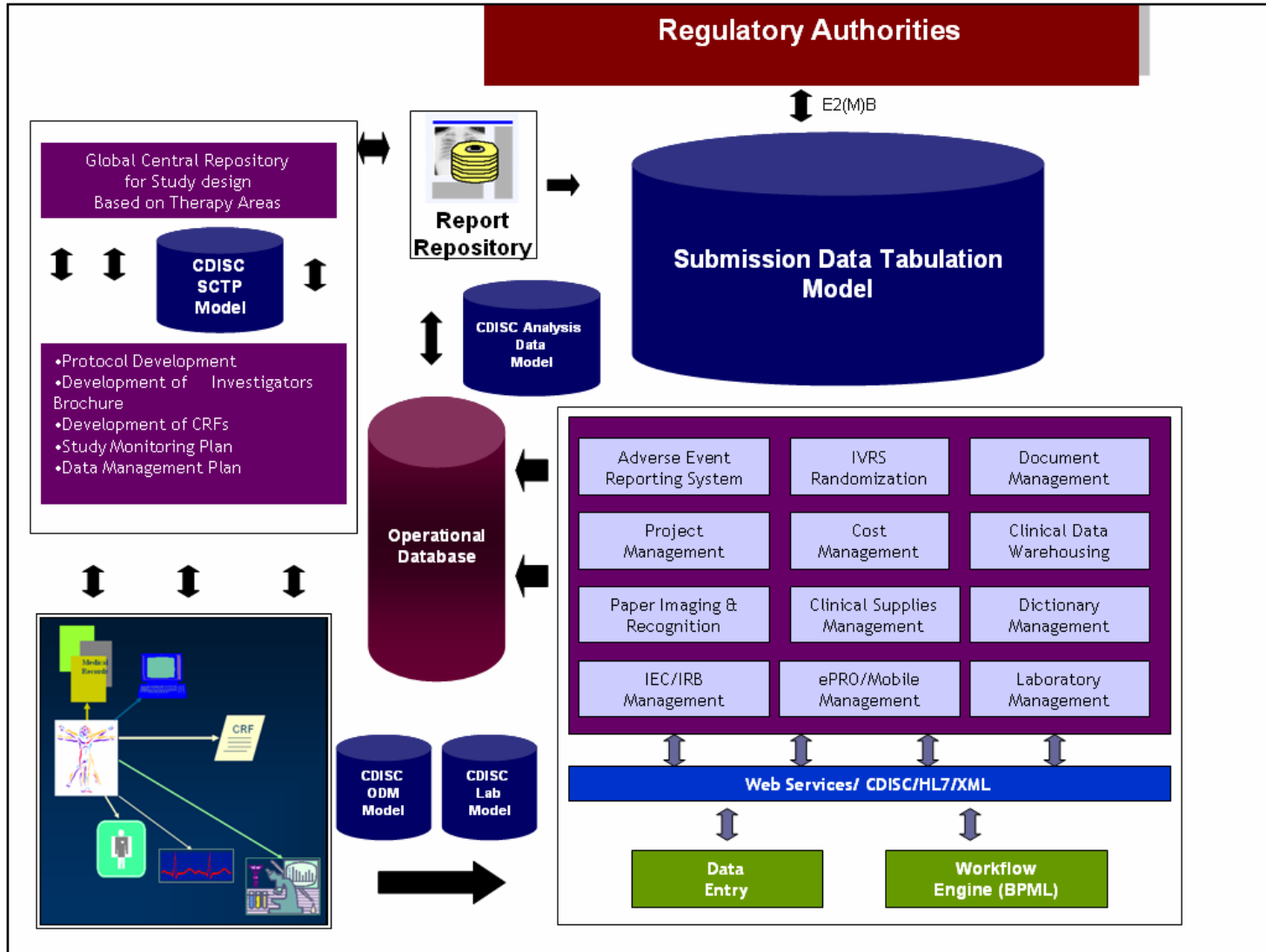

Employment Facts & Trends



- ↙ Wages are up; Productivity is rising; Inflation is in check
- ↙ Living in a new economy
 - ↙ powered by technology
 - ↙ fueled by information
 - ↙ driven by knowledge
 - ↙ a new century with new opportunities

Summary



- ↙ Industry is in flux
 - ↙ More trials
 - ↙ More speed
 - ↙ More burnout
- ↙ Jobs and roles are changing
 - ↙ 2/3 have had recent major role changes
 - ↙ 1/2 have recently changed jobs
 - ↙ Pace will only accelerate
 - ↙ Blurring of roles, end of road warrior?